

## MIDIROLLER Specification

## **MIDIROLLER ADVANTAGES:**

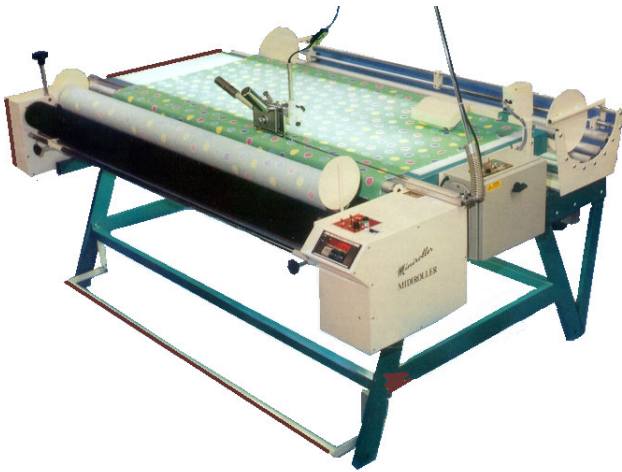

- \*Cradle Unroller (no centre pole)-  
QUICK to load or unload
- \*Surface roller re-wind (no centre pole)-just use a new cardboard tube - quick & easy
- \*Wide horizontal inspection surface
- \*Optional electronic measuring
- \*Complete with Cutter
- \*Optional powered feed & reverse
- \*Ergonomic design for operator with good loading, unloading & operating height

### **DESIGNED SPECIFICALLY FOR THE CUT LENGTH TRADE**

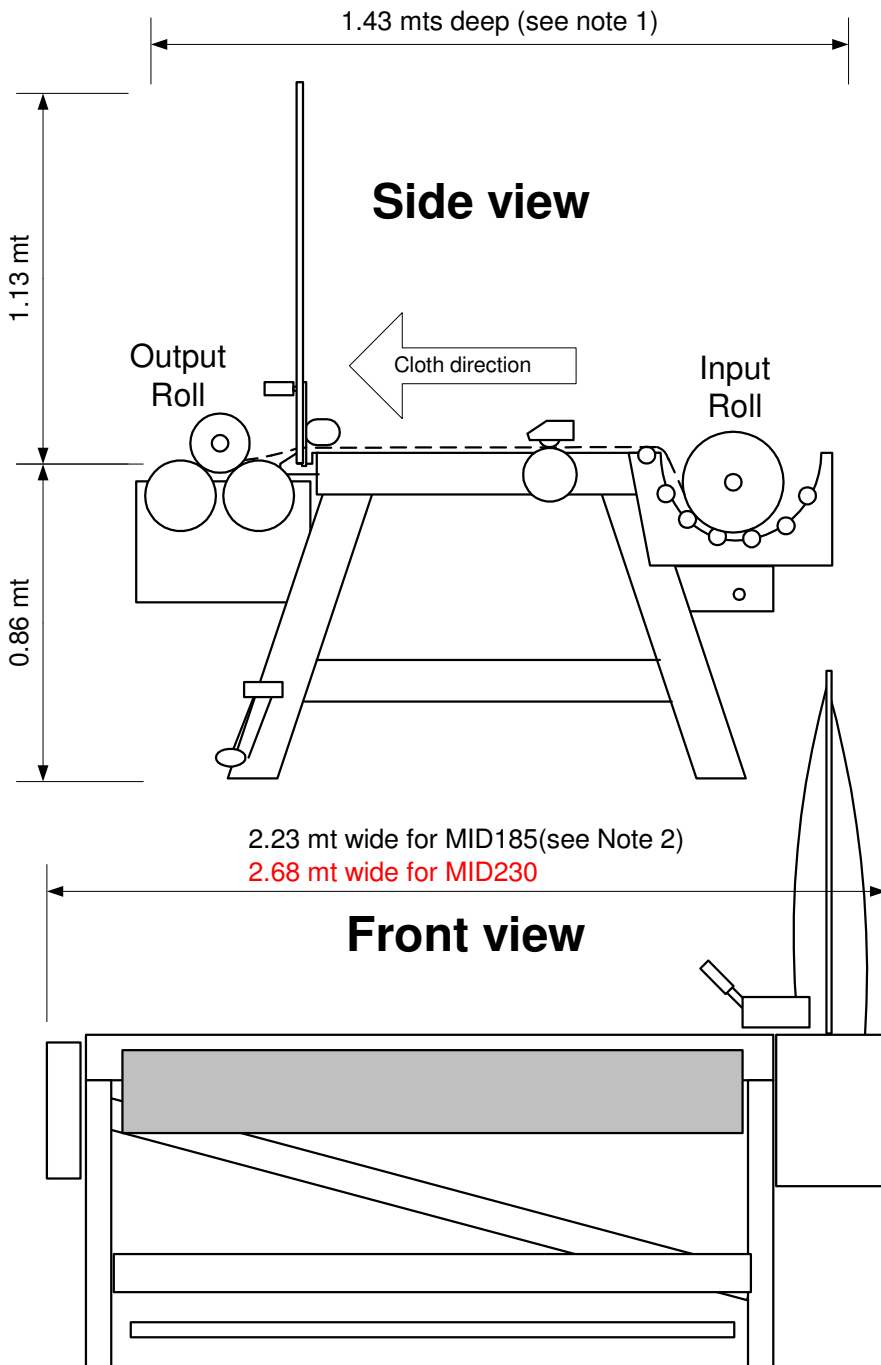

#### Standard Specification (subject to options)

- Input Cloth Roll: **Max 50 kg**
- Input Diameter: **Max 300mm (12")**
- Optional Creel sizes:  
**380mm(15"),500mm(20")**
- Output Diameter: **Max 300mm (12")**
- Lights : **Four** flourescent tubes,  
horizontal screen depth **550mm.**
- Motor :4000/**100rpm**, 7.9nm, 200watts  
(1/4 hp), 210vdc,1ph 50hz, 1.5amp
- Cutter :**Electric motor 220vac**,manual  
pull across, 4 sided 100mm blade.
- Surface Driven Rollers: Standard  
Diameter: **165mm(6.5")**.
- Gap: **32mm**(can be less to order)
- Variable Speed: **Full width foot bar**

#### Note 1.

- Depth : 1.43mt for 300mm creel
- 1.50 mt for 380mm creel
- 1.63 mt for 500mm creel

#### Note 2.

- Width: Equals width of maximum  
Cloth width + 380mm
- eg. MID185= 1850+380=2230mm